

## CT970-48 LANforge ICE 48-port WAN Emulator

The CT970-48 is an excellent choice for high-density WAN emulation. The CT970-48 is a set of 2 machines: One LANforge machine to do the WAN emulation and bridging, and an off-the-shelf managed ethernet switch supporting 802.1Q VLANs. The LANforge machine is a 1U rackmount and the 48-port ethernet switch is a 2U rackmount unit. The user's stations plug into the ethernet switch and speak regular ethernet (no 802.1Q VLAN support is required in the devices-under-test.) The WAN emulation, bridging, and optional virtual router configuration is all managed through the LANforge-GUI. This same general configuration can support 24, 96 and other amounts of WAN emulations: Contact your sales representative for pricing and configuration details.

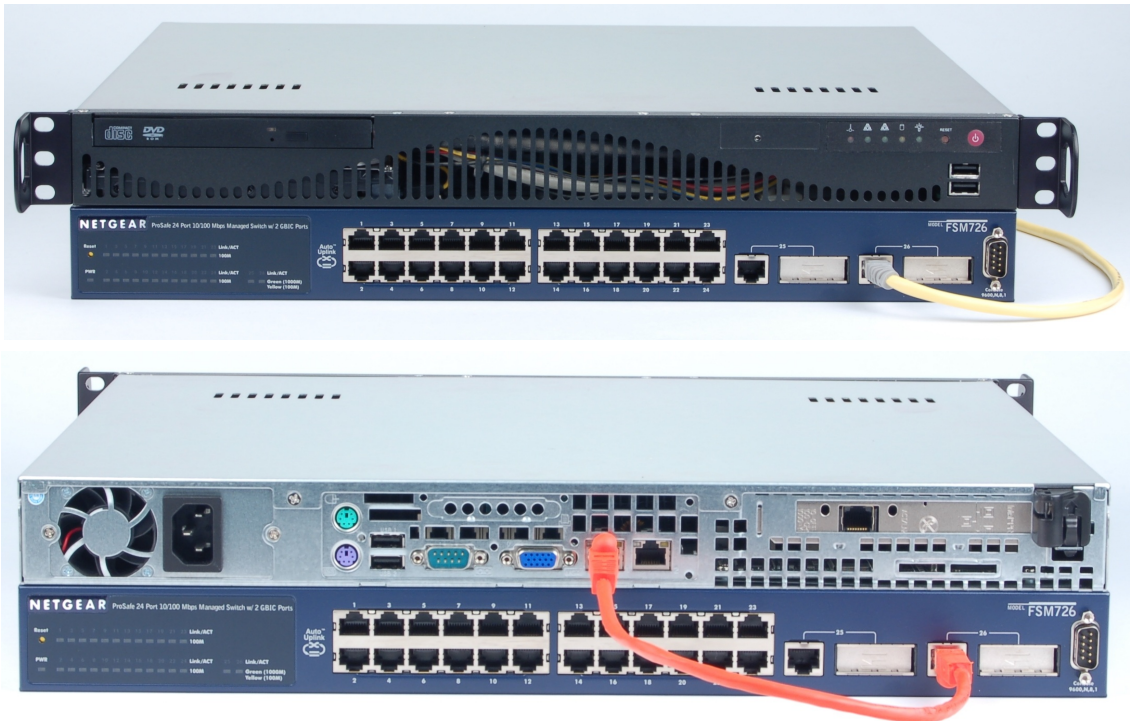

NOTE: This product may have a different hardware configuration than the system pictured above.  
Refer to your official quote for details.



## LANforge-ICE multi-port WAN emulator system.

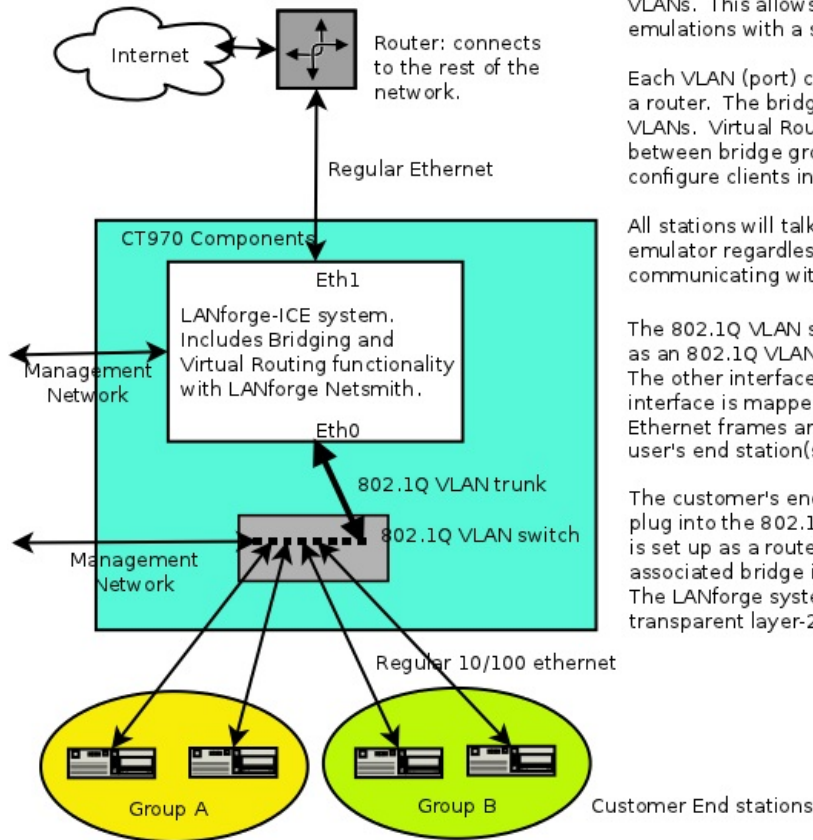

The LANforge-ICE system can have a large number of 802.1Q VLAN interfaces. Each physical port on the VLAN switch maps to a separate VLAN, and the LANforge-ICE WAN emulation is applied to specific VLANs. This allows a large number of distinct WAN emulations with a single LANforge machine.

Each VLAN (port) can be associated with a bridge or a router. The bridge group can contain one or more VLANs. Virtual Routers can be used to provide routing between bridge groups. This allows the user to configure clients into one or more broadcast domains.

All stations will talk through the LANforge-ICE WAN emulator regardless of which other stations they are communicating with.

The 802.1Q VLAN switch has one interface configured as an 802.1Q VLAN trunk. This port connects to LANforge. The other interfaces will be configured such that each interface is mapped to a particular VLAN. Un-tagged Ethernet frames are sent to and received from the user's end station(s) and the up-stream network.

The customer's end stations speak regular Ethernet and plug into the 802.1Q VLAN switch. If the LANforge system is set up as a router, the end stations will use their associated bridge interface as the default gateway. The LANforge system can also be configured as a transparent layer-2 bridge

## LANforge Netsmith Diagram for CT970 Configuration with Routing

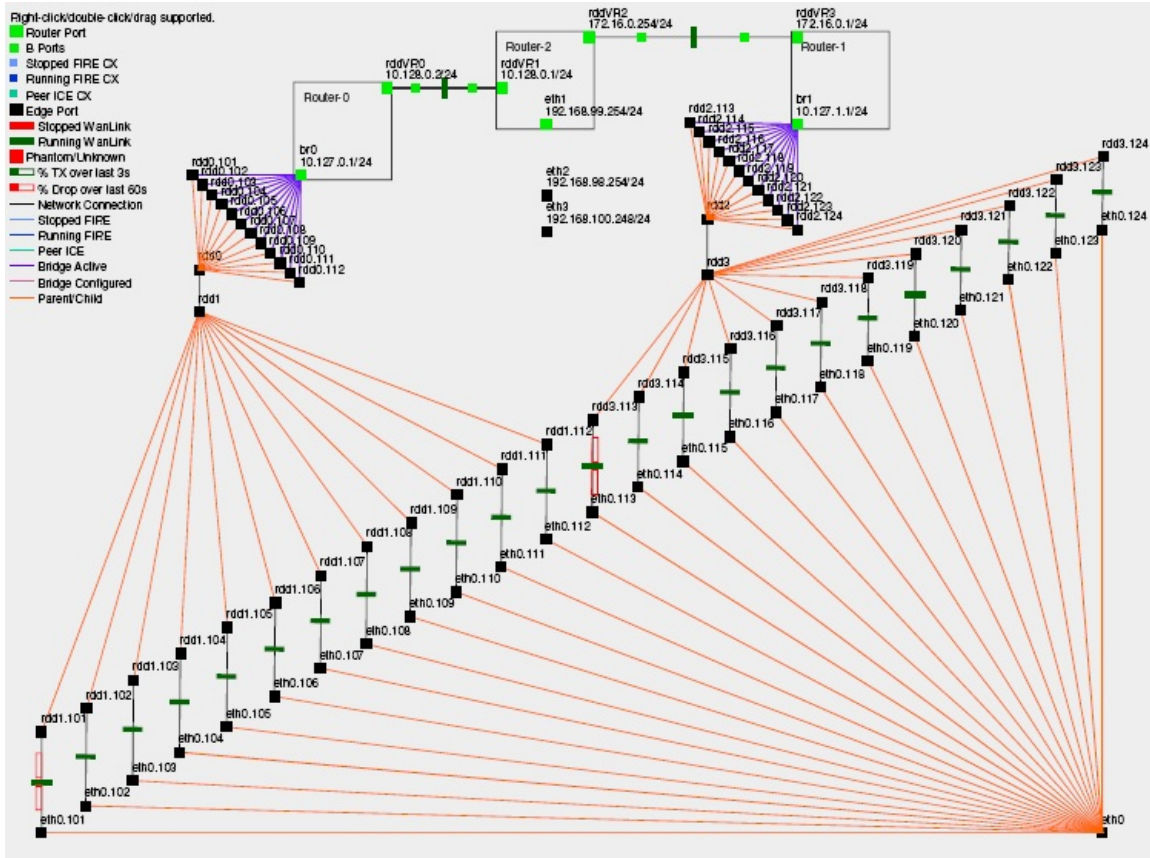

Candela Technologies Inc., 2417 Main Street, Suite 201, P.O. Box 3285, Ferndale, WA 98248, USA  
[www.candelatech.com](http://www.candelatech.com) | [sales@candelatech.com](mailto:sales@candelatech.com) | +1 360 380 1618

## Quick Start Guide

1. Connect Management ethernet port on the LANforge machine to Management network or management PC. If connecting directly to a PC, an ethernet cross-over cable should be used. Or, connect VGA, Keyboard, and Mouse to the chassis and manage it locally.
2. Connect 802.1Q VLAN switch's trunk port to eth2 of the LANforge machine. This is the VLAN trunk between the LANforge machine and the VLAN switch.
3. Connect port eth3 of the LANforge machine to your network switch or router leading towards the internet or network core.
4. Connect Clients to the ports on the 802.1Q VLAN switch. Each port on the switch is configured to bridge regular un-tagged ethernet frames to one of the VLANs on the trunk port leading to the LANforge machine.
5. Connect power to the units and turn them on. The order in which they are booted does not matter.
6. If managing remotely, install the LANforge-GUI on a separate management PC or Laptop. Windows and Linux GUIs are supported: Select the correct one from the CDROM or Candela Technologies Download page and install it.
7. The CT970-48 should now boot. If DHCP is enabled on the Management network, the CT970-48 LANforge machine will automatically acquire an IP address. If DHCP is not available, the IP address will be set to 192.168.1.101 by the LANforge start scripts.
8. Start the LANforge-GUI on the management PC, or the CT970-48 LANforge server if managing locally, and click the 'Discover' button. It should find the CT970-48 LANforge appliance and add the IP address to the drop-down box in the Connect widget. Press 'Connect' and you will be connected to the CT970-48.

9. Select the WanLinks tab in the GUI. One or more of the pre-configured tests should already be running. You may double-click the row in the top section to modify the configuration. You can also view a real-time report of the test with the 'Display' button. Any modifications take place immediately after you click 'Submit'.
10. For a global view of the system and Virtual Routing features, click the Netsmith button on the Status panel or Resource panel.

Candela Technologies Inc., 2417 Main Street, Suite 201, P.O. Box 3285, Ferndale, WA 98248, USA  
 www.candelatech.com | sales@candelatech.com | +1 360 380 1618

## LANforge-ICE Related Screen Shots

### WanLinks Tab

The screenshot displays the LANforge Manager interface, Version 5.2.4, with the WANLinks tab selected. The interface includes a menu bar (Control, Reporting, Tear-Off, Help), a toolbar with buttons like Stop All, Restart Manager, Refresh, and HELP, and a series of tabs for different test categories. The WanLinks tab is active, showing a table of test configurations and a detailed statistics table below it.

**WanLinks for Selected Test Manager**

Name	EID	K-M	State	Endpoints (A <-> B)	Pkt Tx A->B	Pkt Tx A<-B	Rate A->B	Rate A<-B	Rpt Timer
VRWL-1.1.000	6.22	✓	Run	VRWL-1.1.000-A ...	565,080	439,422	1,000,000,000	1,000,000,000	1.00
VRWL-1.1.001	6.3	✓	Run	VRWL-1.1.001-A ...	4,054,185	3,658,228	1,000,000,000	1,000,000,000	1.00
VRWL-1.1.002	6.2	✓	Run	VRWL-1.1.002-A ...	18,632	18,593	44,736,000	44,736,000	1.00
VRWL-1.1.003	6.4	✓	Run	VRWL-1.1.003-A ...	3,657,007	4,040,390	1,000,000,000	1,000,000,000	1.00

**All WanLink Endpoints**

WPs	Name	Run	Script	Max Rate	Tx Pkts	Rx Pkts	Tx Rate	Tx Drop %	Dropped	Tx-Failed	Failed-Late	Tx Bytes
+	VRWL-1.1.0...	✓	Stopped	1,000,000,...	439,422	565,088	1,014,228	0	0	0	0	653,589,...
+	VRWL-1.1.0...	✓	Stopped	1,000,000,...	565,080	439,434	1,020,730	0	0	9	0	843,838,...
+	VRWL-1.1.0...	✓	None	1,000,000,...	3,658,228	4,054,215	69,677	0	0	0	0	782,190,...
+	VRWL-1.1.0...	✓	None	1,000,000,...	4,054,185	3,658,203	77,642	0	0	0	0	866,984,...
+	VRWL-1.1.0...	✓	None	44,736,000	18,593	18,613	85,816	0	0	0	0	3,980,56...
+	VRWL-1.1.0...	✓	None	44,736,000	18,632	18,612	85,849	0	0	0	0	3,988,51...

Logged in to: 192.168.100.138:4002 as: Admin

## WanLink Display

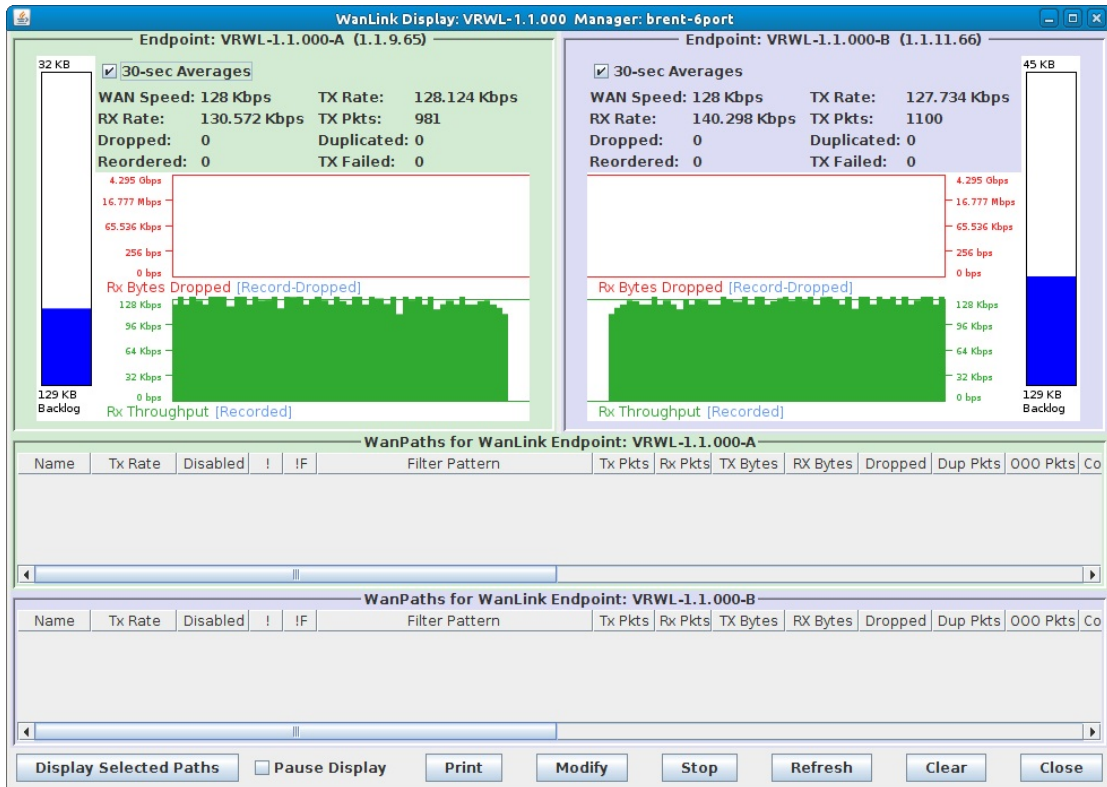

## Create/Modify WanLink Window

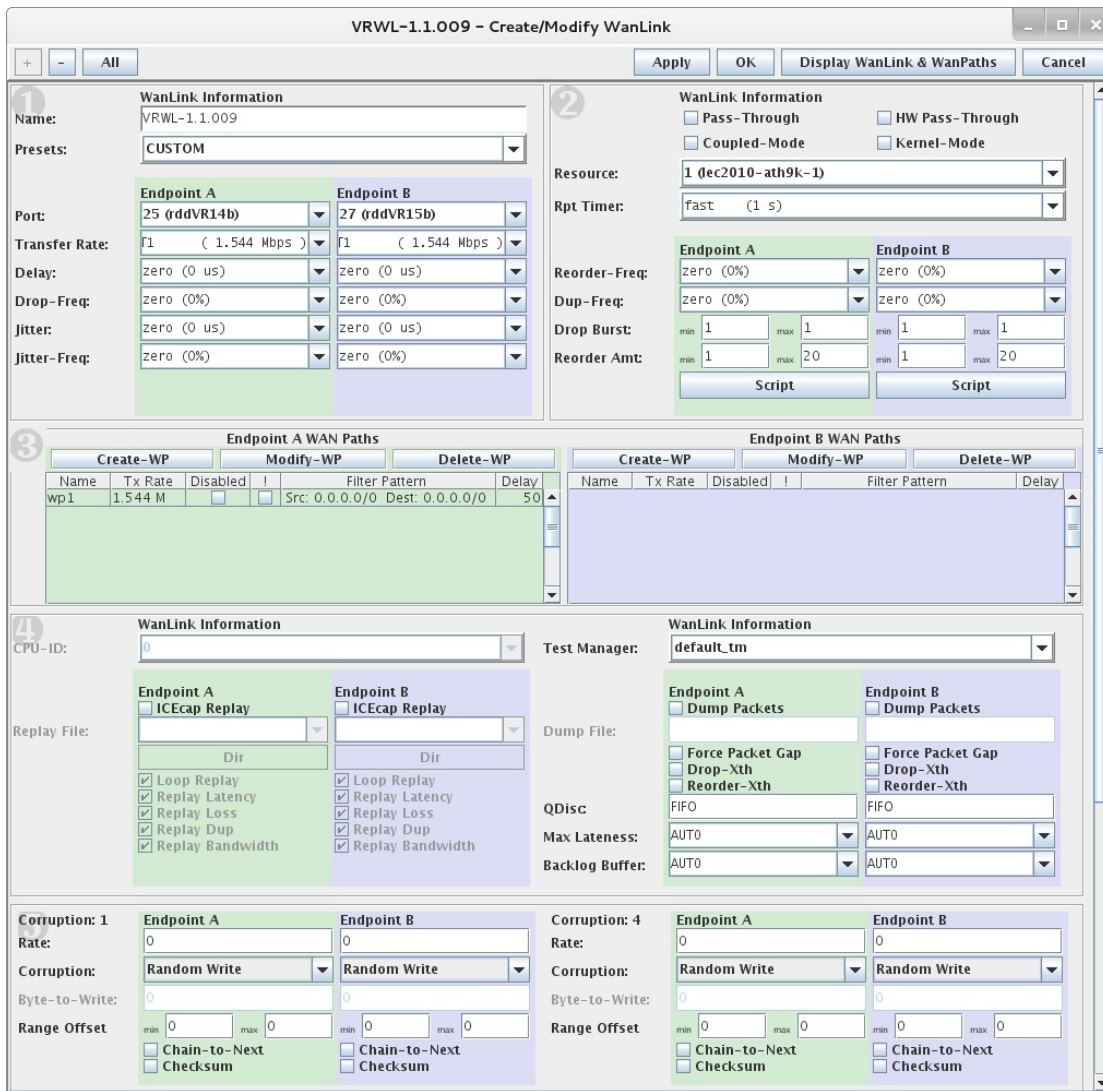

Candela Technologies Inc., 2417 Main Street, Suite 201, P.O. Box 3285, Ferndale, WA 98248, USA  
 www.candelatech.com | sales@candelatech.com | +1 360 380 1618

## Software Features

1. General purpose WAN and Network impairment emulator.
2. Able to simulate 48 independent DS1, DS3, DSL, CableModem, Satellite links and other rate-limited networks, from 10bps up to 45Mbps (full duplex). Total aggregate throughput will not exceed 1Gbps.
3. Can modify various network attributes including: network-speed, latency, jitter, packet-loss, packet-reordering, and packet-duplication.
4. Supports Packet corruptions, including bit-flips, bit-transposes and byte-overwrites.
5. Supports WanPath feature to allow configuration of specific behavior between different IP subnets, MAC addresses or other packet filters using a single pair of physical interfaces. WanPath support may

- require purchase of additional WanPath licenses, please ask your sales contact for more information.
6. Supports routed and bridged mode for more flexibility in how you configure your network and LANforge-ICE.
  7. Supports WAN emulation across virtual 802.1Q VLAN interfaces more efficient use of limited physical network interfaces.
  8. Supports 'WAN-Playback' allowing one to capture the characteristics of a live WAN and later have LANforge-ICE emulate those captured characteristics. The playback file is in XML format, and can be easily created by hand or with scripts. The free LANforge-ICEcap tool can be used to probe networks and automatically create the XML playback file.
  9. Allows packet sniffing and network protocol decoding with the integrated [Wireshark](#) protocol sniffer.
  10. Includes comprehensive management information detailing all aspects of the LANforge system including processor statistics, test cases, and Ethernet port statistics.
  11. GUI runs as Java application on Linux, MAC and Microsoft Operating Systems (among others).
  12. GUI can run remotely, even over low-bandwidth links to accommodate the needs of the users.
  13. Central management application can manage multiple units, tests, and testers simultaneously.
  14. Includes easy built-in scripting to automatically iterate through bandwidth, latency and other settings. Advanced programmatic scripting over a TCP socket also supported and example perl libraries and scripts are included.
  15. Automatic discovery of LANforge resources simplifies maintenance and configuration of LANforge test equipment.

## Hardware Specification

### LANforge Server Specifications

1. Gigabit-class Intel Multi-Core 1U rackmount server.
2. Operating System: Fedora Linux with customized Linux kernel.
3. Up to 6 PCIe Intel Pro/1000 10/100/1000 Ethernet ports. Additional 10/100/1000 Ethernet interface for management.
4. High-availability Ethernet hardware bypass option available.
5. 2-port 10G fiber or copper CX4 option available.
6. Multi-Core Intel processor.
7. One PCIe slot.
8. 2 GB or more RAM.
9. 80 GB or larger Hard Drive.
10. Solid State Drive option available.
11. Standard US or European power supply (automatically detects EU v/s US power).
12. Weight: 18 lbs or 8.2 kg.
13. Dimensions: 17 x 14 x 1.75 inches (14-inch deep 1U rackmount server) Metric: 432 x 356 x 44 mm.
14. ROHS compliant.

### Ethernet Switch Specifications

1. 48-port 802.1Q VLAN switch with 2 GigE uplinks.
2. 48 10/100/1000 Autonegotiating RJ45 Ethernet interfaces.
3. 2 10/100/1000 Autonegotiating RJ45 Ethernet interfaces.
4. Dimensions: 17 x 10 x 3.2 inches (Standard 10-inch deep 2U rackmount) Metric: 432 x 254 x 81 mm.

---

## Additional Feature Upgrades

Unless otherwise noted in the product description, these features usually cost extra:

- WanPaths (LANforge-ICE feature set)
- Virtual Interfaces: MAC-VLANs, 802.1Q VLANs, WiFi stations, etc
- LANforge FIRE traffic generation.
- VOIP: Each concurrent call over the included package requires a license.
- VoIP-Mobile Audio Quality Testing using POLQA/PESQ.
- Mobile-Mobile Audio Quality Testing using POLQA/PESQ.
- Armageddon: Each pair of ports requires a license if not already included.
- RF Chambers for WiFi testing.
- External battery pack: 12+ hours for CT520, CT523, CT92X and other platforms.

---

Candela Technologies Inc., 2417 Main Street, Suite 201, P.O. Box 3285, Ferndale, WA 98248, USA  
www.candelatech.com | sales@candelatech.com | +1 360 380 1618

Last modified: Fri Apr 12 15:32:55 PDT 2024