

## Advanced configuration options for TR-398 Issue-2/3 and Mesh on a 4-Chamber Setup

**Goal:** Explore advanced configuration options for a TR398 issue-3 mesh testbed. The testbed in this example supports both 32 real tri-band radios as well as 6 virtual-station dual-band radios. See the [TR398 testbed page](#) for more information.

In this test scenario, a LANforge cluster (of three 523c and 3 521b systems) is used to emulate different station and AP scenarios and generate and receive traffic with a set of 3 meshed APs. This example assumes user has some experience with Chamber View and TR398, and has an appropriate LANforge TR398 testbed. Please contact support@candelatech.com for assistance in setting up the TR-398 testbed.

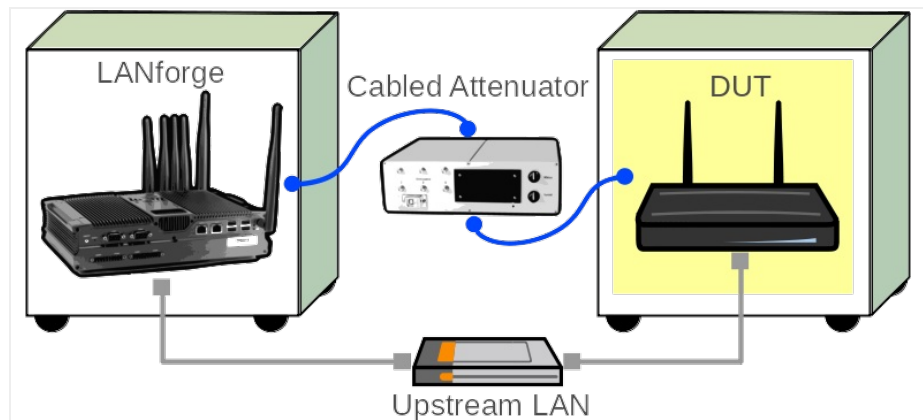

### 1. System configuration overview.

- A. The status panel shows all 6 LANforge systems connected and available.

The screenshot shows the LANforge Manager Version(5.4.6) interface. The top menu bar includes 'Control', 'Reporting', 'Windows', 'Info', and 'Tests'. Below the menu bar, there are several tabs: 'Chamber View', 'Stop All', 'Restart Manager', 'Refresh', and 'HELP'. The main interface is divided into several sections:

- License Info:** Licenses expire in: 611 days. TR-398. Support expires in: 611 days.
- Current Users:** \* Admin from:10.253.1.98, Admin from:192.168.100.195, gnusever from:127.0.0.1
- Saved Test Configurations:** Configuration: DFLT, Download DB, Show Progress, Delete, Save DB Name: [input field], Save, Overwrite, DUT, Chamber, Profile.
- Realm 32:** A grid of resources. Resource 1 is labeled 'Manager/Resource 1' and 'Netsmith'. Resources 2 through 6 are labeled 'Resource 2' through 'Resource 6' and 'Netsmith'. Each resource has a status indicator (green, red, or blue) and a 'Netsmith' button.

Logged in to: 192.168.100.228:4002 as: Admin



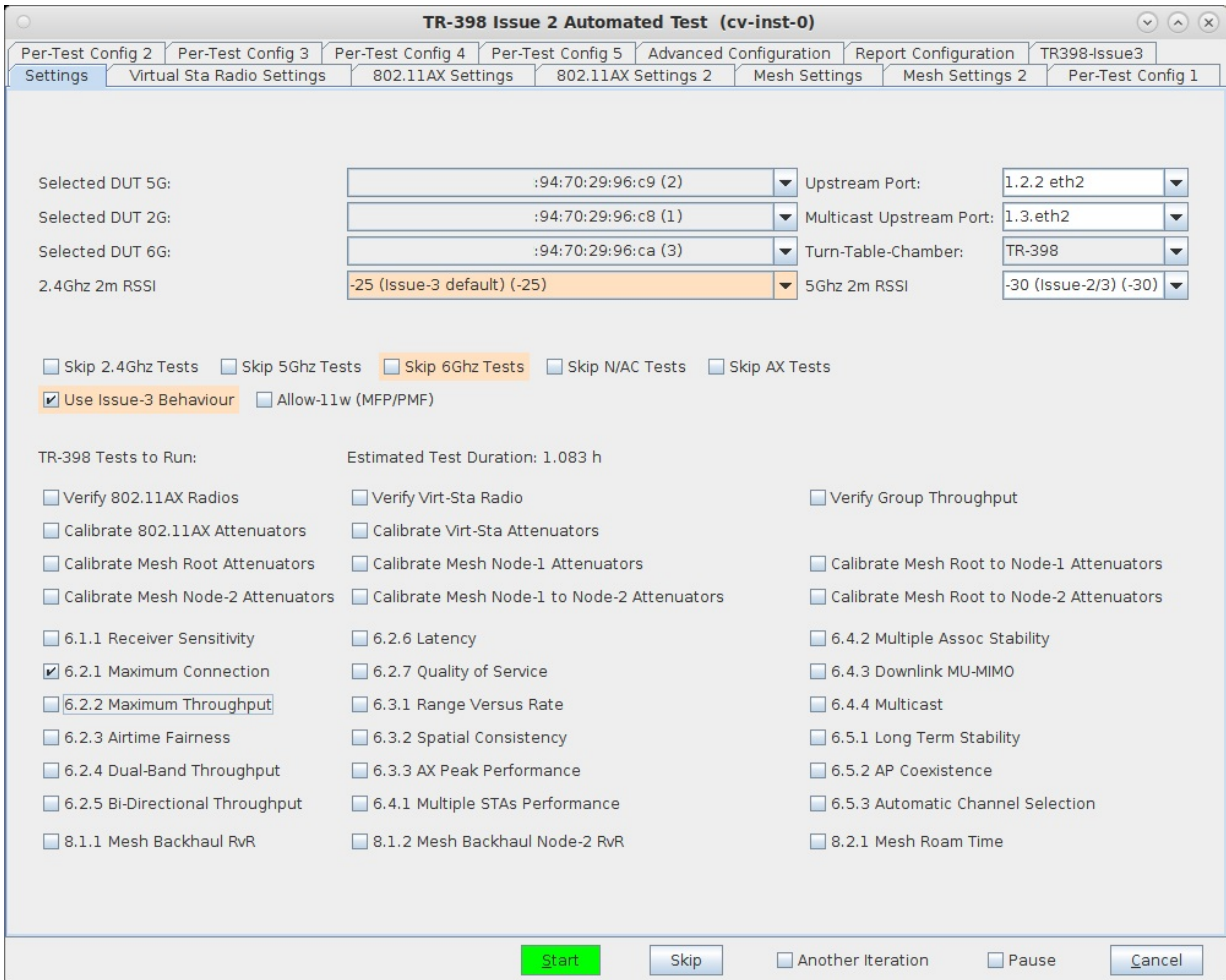

- The Virtual Sta Radio settings tab is for the radios supporting virtual stations (MTK7915 4x4 dual-band AX in this example). The zero-attenuation RSSI values are calibrated during testbed configuration. See [TR398 calibration cookbook](#) for instructions on how to do this.

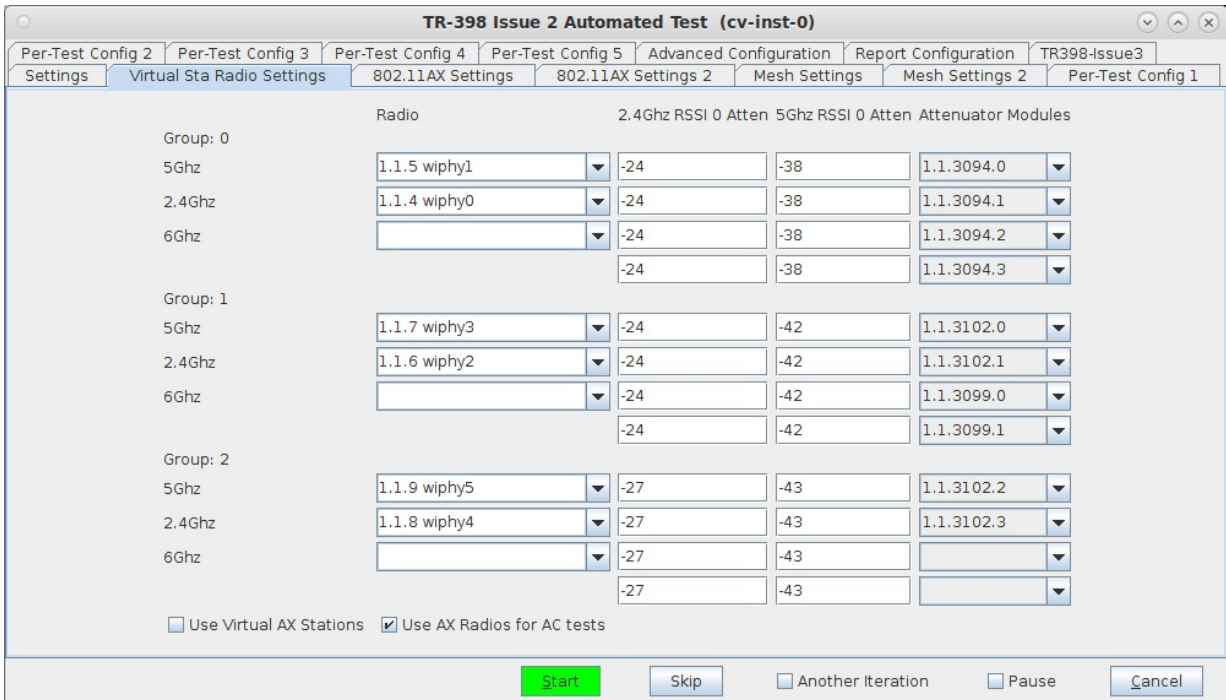

- The 802.11AX Settings tab is for configuring non-virtual-station radios, Intel AX210 in this case.



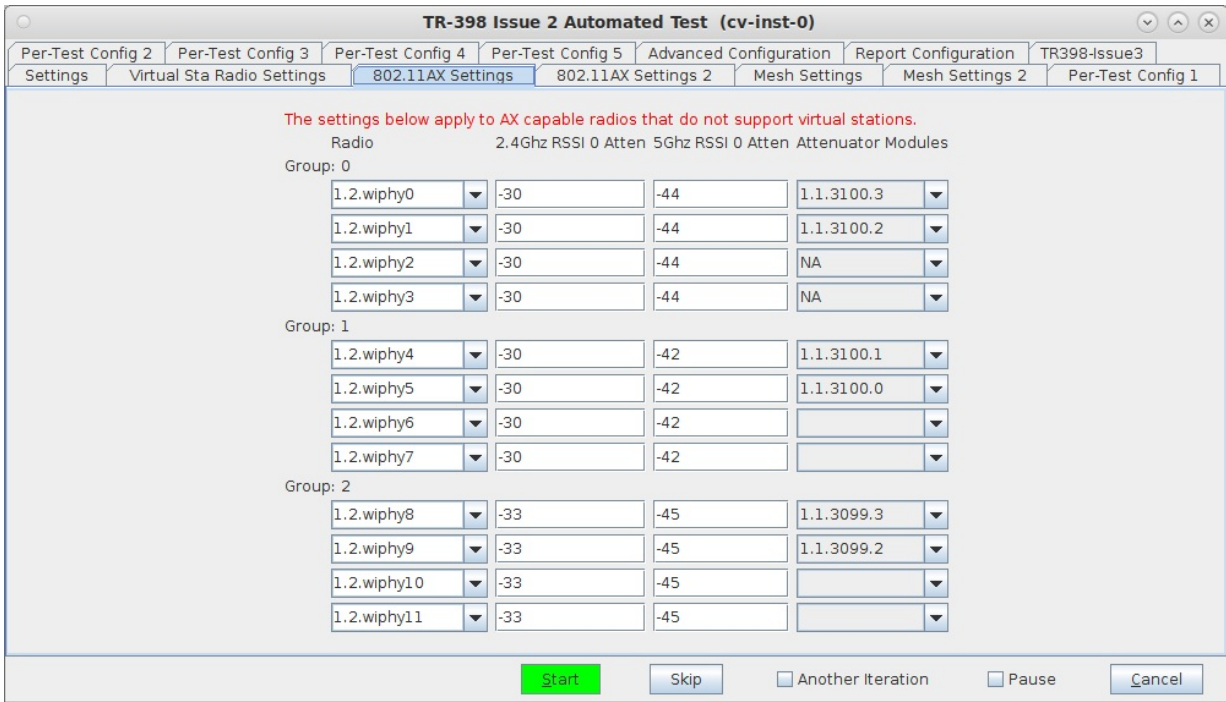

- The 802.11AX Settings 2 tab is for configuring additional non-virtual-station radios, Intel AX210 in this case. Some testbeds will have different attenuators for groups 2-7. The testbed in this example uses splitter-combiners so that all radios in groups 2-7 go through the same attenuator, so there are no attenuators configured on this second AX settings tab.

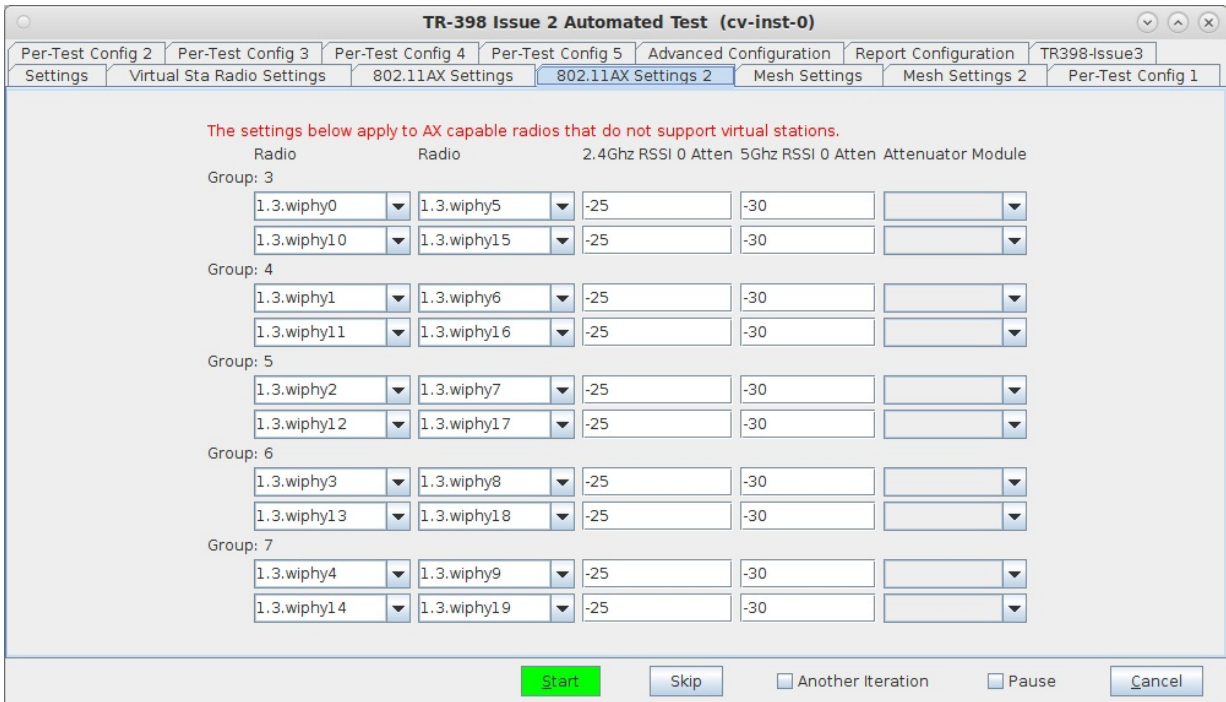

- The Mesh Settings tab has information needed to run the Mesh test cases. This includes the DUT information for the node-1 and node-2 mesh chambers, attenuator mappings between chambers, and some scanning configuration.

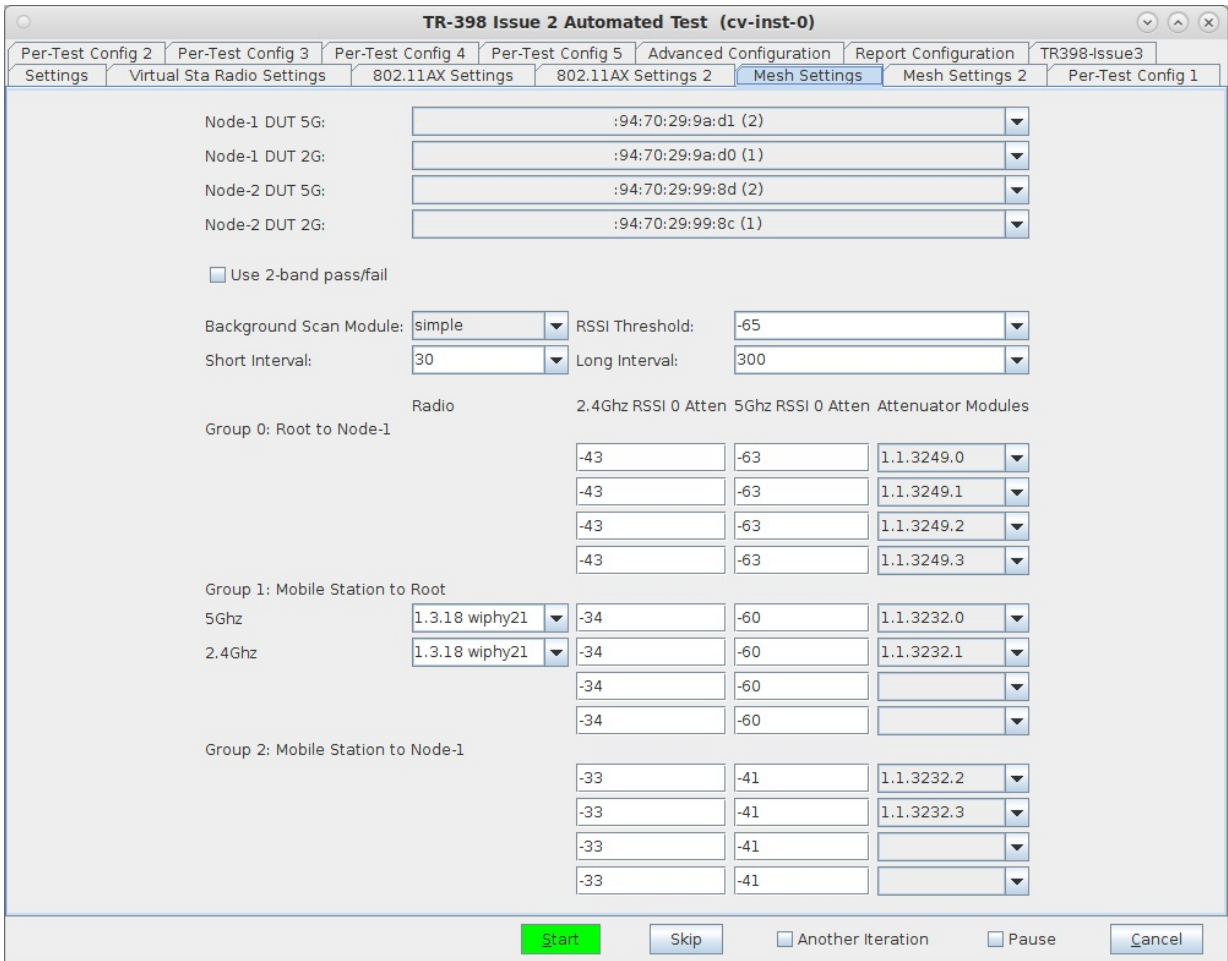

7. The Mesh Settings 2 tab has additional mapping information needed for a 3-node mesh testbed.

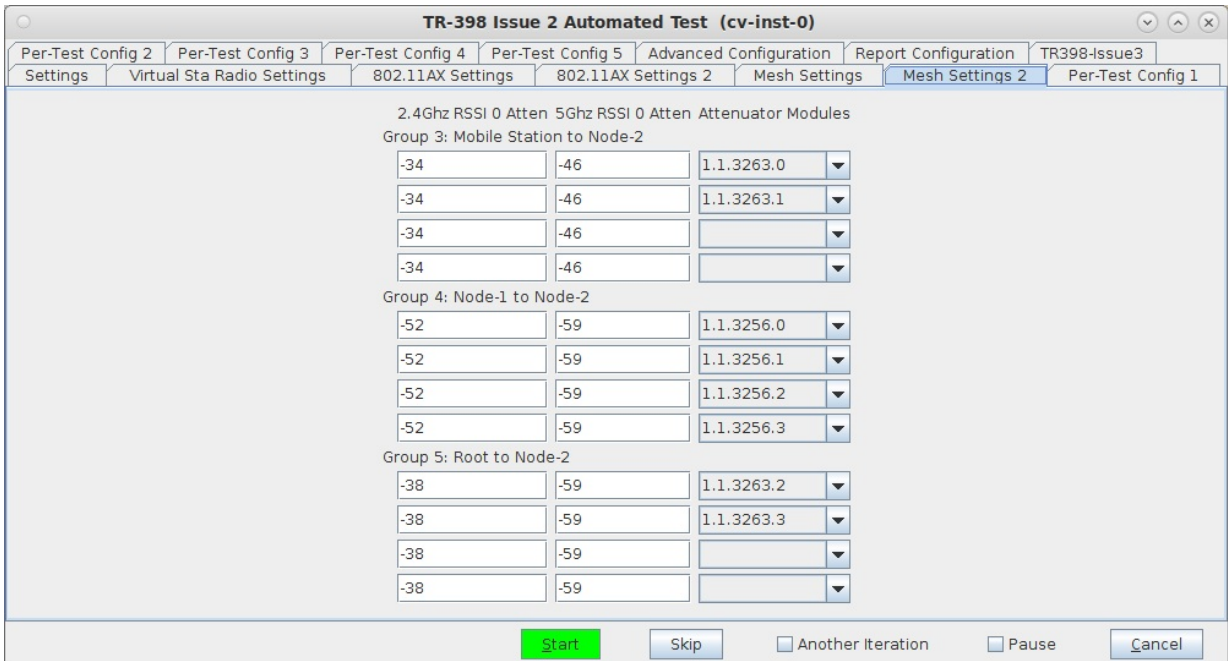

8. The Per-Test Config tabs provide tunable settings for individual test cases. Each entry field will have a tool-tip to explain what it does in more detail. The sections will only be active if the respective test case is selected on the Settings tab.

**TR-398 Issue 2 Automated Test (cv-inst-0)**

Per-Test Config 2 | Per-Test Config 3 | Per-Test Config 4 | Per-Test Config 5 | Advanced Configuration | Report Configuration | TR398-Issue3

Settings | Virtual Sta Radio Settings | 802.11AX Settings | 802.11AX Settings 2 | Mesh Settings | Mesh Settings 2 | Per-Test Config 1

Calibrate Zero Attenuation RSSI

Calibration Mode: 802.11abg | Calibration NSS: NSS-1 (1)

Calibrate against LANforge AP

2.4Ghz LANforge AP Calibration Radio: 1.4.3 wiphy0

5Ghz LANforge AP Calibration Radio: 1.4.4 wiphy1

2.4Ghz Mesh Node-1 LANforge AP Calibration Radio: 1.5.3 wiphy0 | 5Ghz Mesh Node-1 LANforge AP Calibration Radio: 1.5.3 wiphy0

2.4Ghz Mesh Node-2 LANforge AP Calibration Radio: 1.6.3 wiphy0 | 5Ghz Mesh Node-2 LANforge AP Calibration Radio: 1.6.4 wiphy1

6.1.1 Receiver Sensitivity Test

Stop RX-Sens at pass | RxSens Start Step: 4

RxSens-Rate: 65% | RxSens Rotation Degrees: 45

6.2.1 Maximum Connection Test (32-STA)

Max-CX Offered Load: 101% (101%) |  Randomize Offered Load |  Allow Maximum NSS |  Enable 6Ghz-80

Use Group-0 Radios |  Use Group-1 Radios |  Use Group-2 Radios

Max-CX 2Ghz N rate: 2Mbps - Default (2 Mbps) | Max-CX 5Ghz AC rate: 8Mbps - Default (8 Mbps)

Max-CX 2Ghz AX rate: 3Mbps - Default (3 Mbps) | Max-CX 5Ghz AX rate: 10Mbps - Default (10 Mbps)

Max-CX 6Ghz AX rate: 20Mbps - Default (20 Mbps) | Ramp Duration: 45 (45 sec)

Max-CX 6Ghz-80Mhz AX rate: 10Mbps - Default (10 Mbps) | STA Count: 32 (32)

6.2.2 Maximum TCP Throughput Test

Throughput N 2Ghz rate: 100Mbps - Default (100 Mbps) | Throughput AC 5Ghz rate: 560Mbps - Default (560 Mbps)

Throughput AX 2Ghz rate: 200Mbps - Default (200 Mbps) | Throughput AX 5Ghz rate: 720Mbps - Default (720 Mbps)

Throughput AX 6Ghz rate: 1.44Gbps - Default (1.44 Gbps)

Start | Skip |  Another Iteration |  Pause | Cancel

9. The Per-Test Config 2 tab.

**TR-398 Issue 2 Automated Test (cv-inst-0)**

Per-Test Config 2 | Per-Test Config 3 | Per-Test Config 4 | Per-Test Config 5 | Advanced Configuration | Report Configuration | TR398-Issue3

Settings | Virtual Sta Radio Settings | 802.11AX Settings | 802.11AX Settings 2 | Mesh Settings | Mesh Settings 2 | Per-Test Config 1

6.2.3 Airtime Fairness Test

ATF Max NSS: 2x2 (2) | ATF Attenuation: Default 0 (0)

6.2.4 Dual-Band Throughput Test

Unlimited TCP Speed |  Enable 2.4-40 + 5G-160 |  Enable 2.4-40 + 6G-160 |  Enable 5G-80 + 6G-160

Low-Band Radio: Default (-1) | High-Band Radio: Default (-1)

6.2.5 Bidirectional UDP Throughput Test

Max allowed packet loss%: 0.01 |  Allow Maximum NSS

Enable 5g-160 |  Enable 6g-80

Skip First Attenuation Step |  Skip Second Attenuation Step |  Skip Third Attenuation Step

6.2.6 Latency Test

One-Way Download Latency

6.2.7 Quality of Service Test

Pass/Fail High-Limit

Start | Skip |  Another Iteration |  Pause | Cancel

10. The Per-Test Config 3 tab allows setting specific attenuations and pass/fail for the RvR and spatial consistency tests.



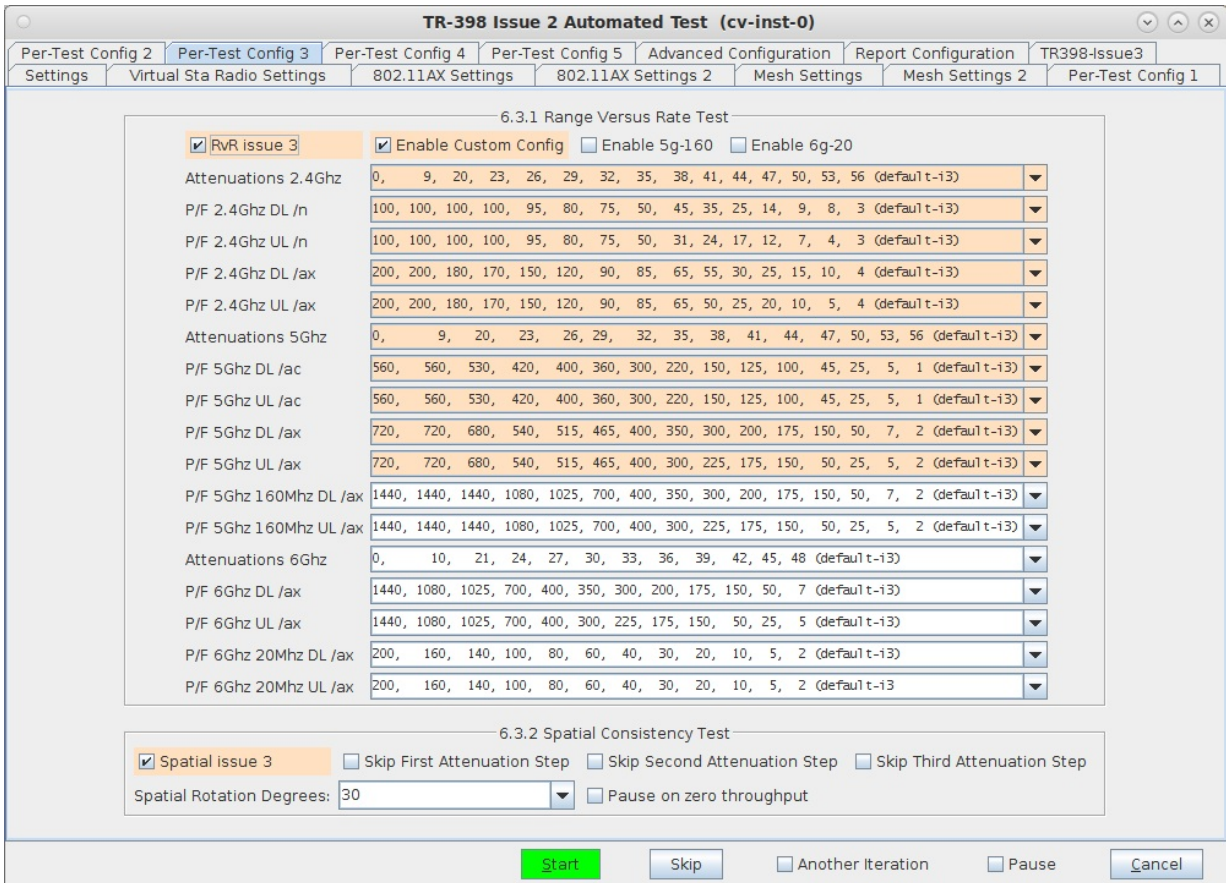

11. The Per-Test Config 4 tab allows tuning the peak-performanc tests and others.

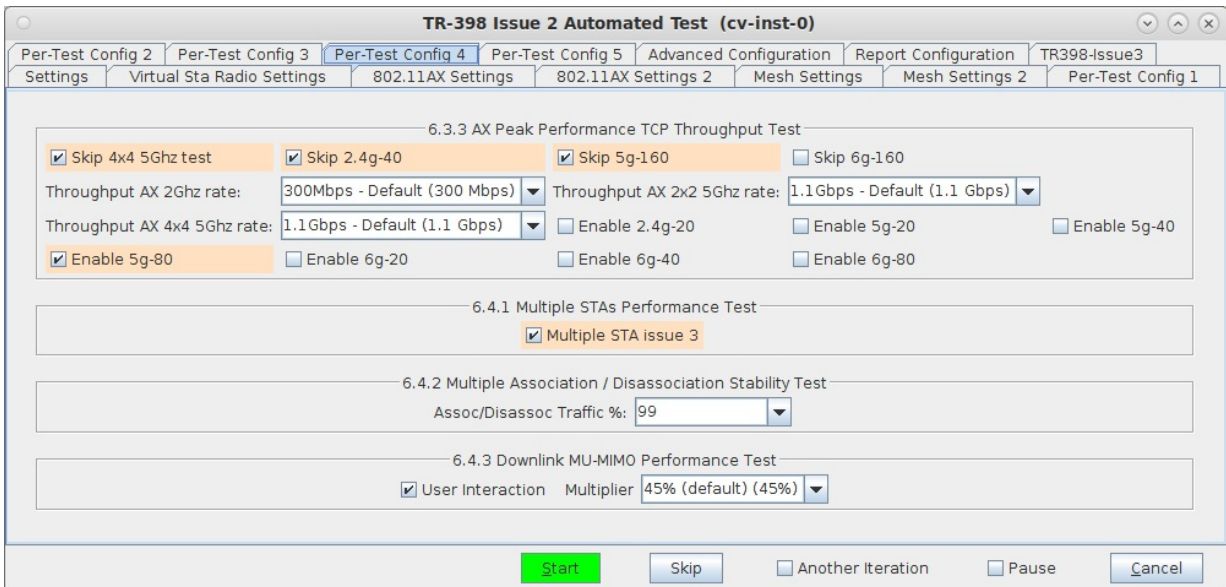

12. The Per-Test Config 5 tab.

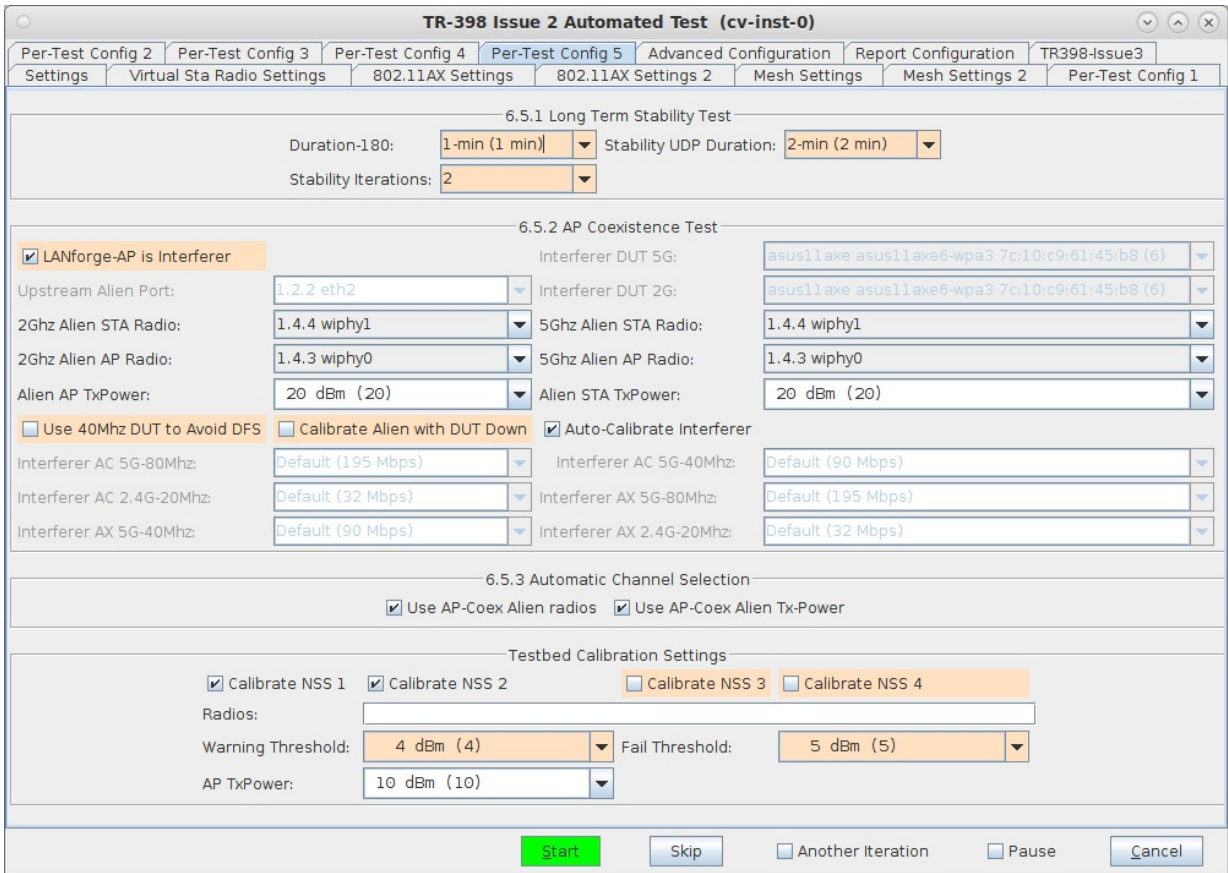

13. The Advanced Configuration tab has settings that apply to many tests. The top section is for saving and loading test configurations. The Import Config window will let one paste in a full or partial test configuration file to apply those changes easily. The Rotation fields at the bottom allow the user to specify optimal rotations to run tests which do not explicitly control the turntable. Use the Rate vs Orientation test to find optimal rotations.

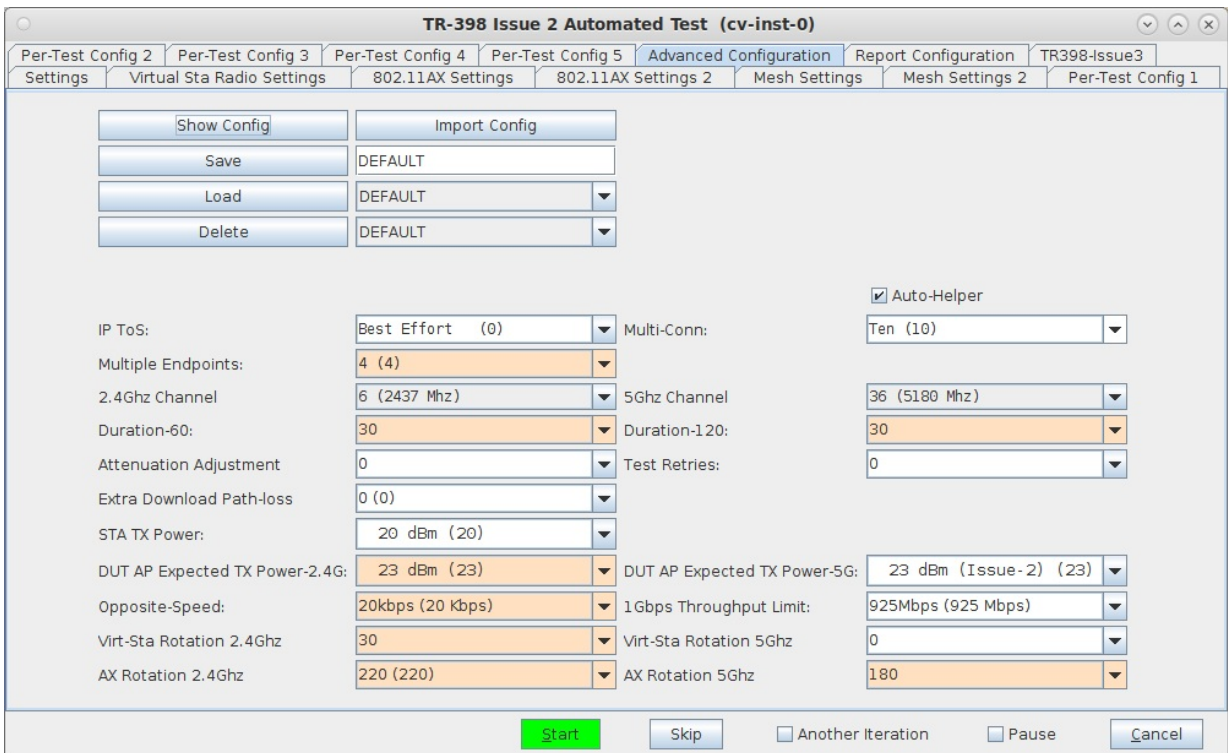

14. The Report Configuration tab allows customizing the report generated by the TR398 test cases..



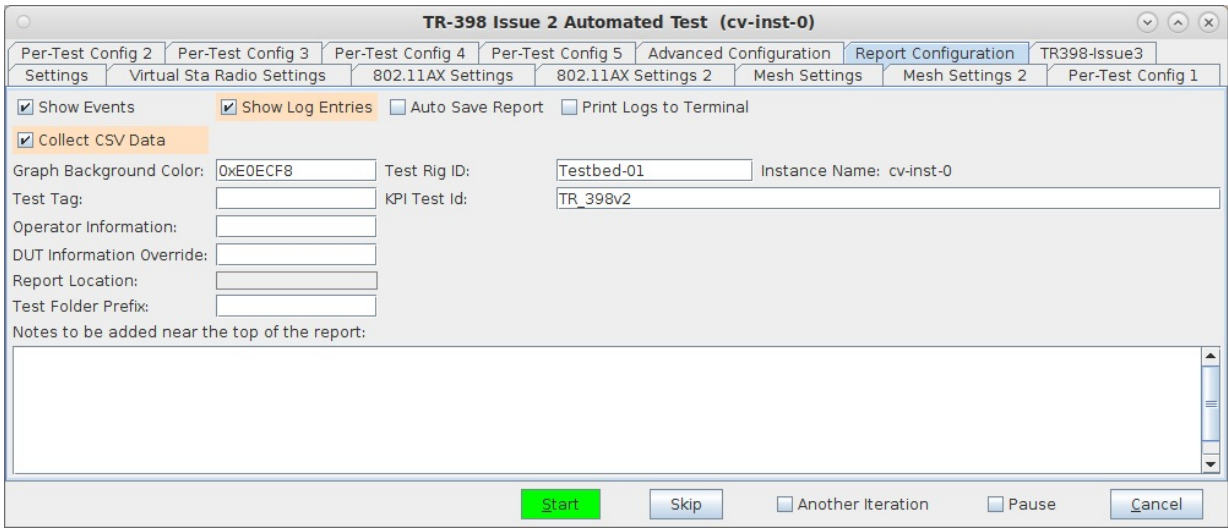

15. The Issue-3 page is for experimental test cases. At time of writing, this tab is not needed. The ATF test case will be executed if the 'Use Issue-3 Behaviour' checkbox is selected on the Settings page.

