

Testing Station Capacity and throughput for a WiFi Device

Goal: Setup and run a WiFi Capacity Test test for an AP using the LANforge CT523c or similar system in order to test how well the AP can handle different amounts of active stations. This is a good test of the AP's scalability and stability.

In this test scenario, the LANforge CT523c is used to create 64 stations and generate packets on the Ethernet port towards the wired side of the AP. The AP will then transmit the frames to the LANforge WiFi stations. LANforge will bring up stations in configured amounts, run a throughput test, and then bring up the next set of stations and repeat until the test is complete. This example assumes you have some experience with Chamber View, and that you have a LANforge system and two isolation chambers like the CT820a. The AP should be in one chamber, the LANforge system is in the other chamber, and the Attenuator (if using one) is cabled between them. Set the Attenuator to desired state before starting the test. Chambers and attenuators are not required for this test, but running inside isolation chambers will usually give you better and more reliable test results. This feature is in LANforge version 5.3.9 and higher.

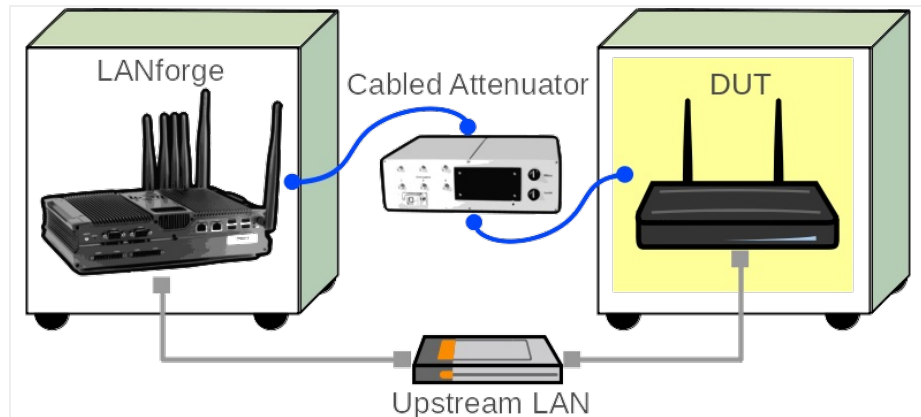

1. Configure Chamber View for WiFi Capacity Test and Similar Tests.

- A. Open Chamber View by clicking on the 'Chamber View' button in the LANforge-GUI. If you have an appropriate scenario already created, then skip to the next section, otherwise you will need to build a scenario that matches your system. You can right-click in Chamber View to create various objects.

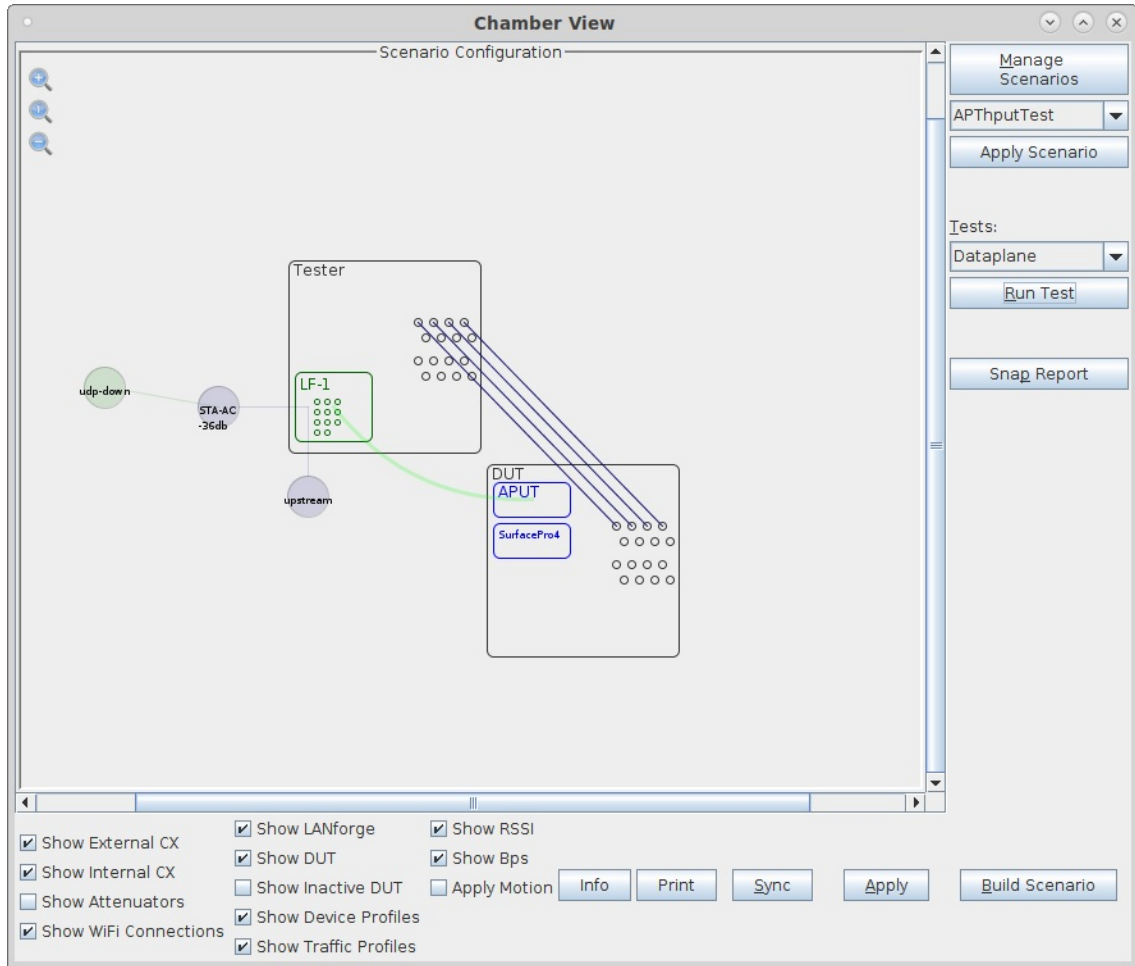

F. Configure an STA profile on the LANforge system.

Create/Modify Profile

Name: Type:

Mode: Antennas:

Instances: Frequency:

SSID:

Pattern:

DHCP Server WEP

WPA WPA2 WPA3 802.11r

802.1x EAP-TTLS Restart DHCP on Connect

Notes:

Buttons:

G. Configure a Chamber View Scenario and add the STA profile (mapped to desired wiphyX radio and DUT). Add an upstream profile mapped to DUT LAN side (or possibly WAN side if that is more appropriate for your DUT). Choose the appropriate quantity of stations for your test case.

Create/Modify Scenario

Scenario Name:

Del	Resource Profile	Mod Amount	Uses-1	Uses-2	Frequency	Maps To
<input checked="" type="checkbox"/>	1.1 STA: STA-AC	64 (64)	wiphy0	AUTO	157 (5785 Mhz)	DUT: APUT Radio-1
<input checked="" type="checkbox"/>	1.1 Upstream: upstream	1 (1)	eth1	AUTO	AUTO (-1 Mhz)	DUT: APUT LAN

Buttons:

2. Use Chamber View to run a WiFi Capacity Test.

- A. Open Chamber View by clicking on the 'Chamber View' button in the LANforge-GUI. Load appropriate scenario or create a new scenario as needed. Apply the Scenario, then Build the scenario.

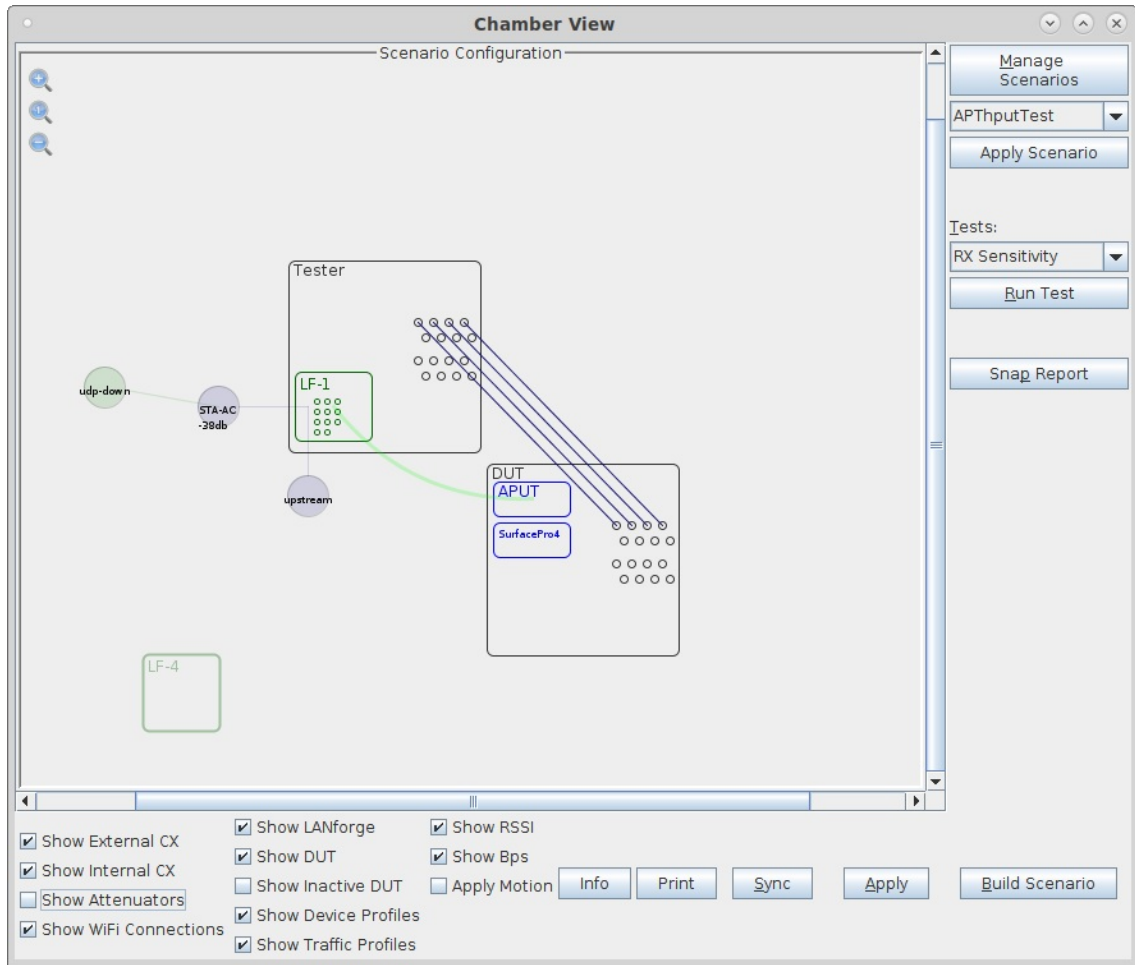

- B. Select the **WiFi Capacity** test and click **Run Test**. You should see the WiFi Capacity Test configuration window pop up. The Ports are normally selected properly based on the Scenario, but you may need to adjust them depending on your goals and scenario. Select the desired throughput and any other configuration changes from the defaults:

The screenshot shows the 'WiFi Capacity Test' configuration window. It has several tabs: 'Settings', 'Select Ports', 'Test Groups', 'PDU Mix Settings', 'Advanced Settings', 'Select Output', and 'Notes'. The 'Settings' tab is active, showing the following configuration:

- Station Increment: 1, 2, 5, 10, 20
- Loop Iterations: Single (1)
- Duration: 15s
- Use Test Groups:
- Subset of Test Group:
- Protocol: UDP-IPv4
- Layer-4 Endpoint: NONE
- Payload Size: AUTO
- MSS: AUTO
- Total Download Rate: 1gbps
- Total Upload Rate: Zero (0 bps)
- Percentage TCP Rate: 10% (10%)
- Buttons: Save, Load, Delete
- Buttons: Start, Close

- C. When the configuration is complete, click the **Start** button (which will change to 'Stop' once start is clicked) to start the test. An interactive report window will be created and will be updated as the test runs. In this particular test, the results are a bit unexpected. Normally rate starts off high and slowly decreases after 5 or 10 stations are active. In this case, we see a falloff after 10, but then it recovers at 60.

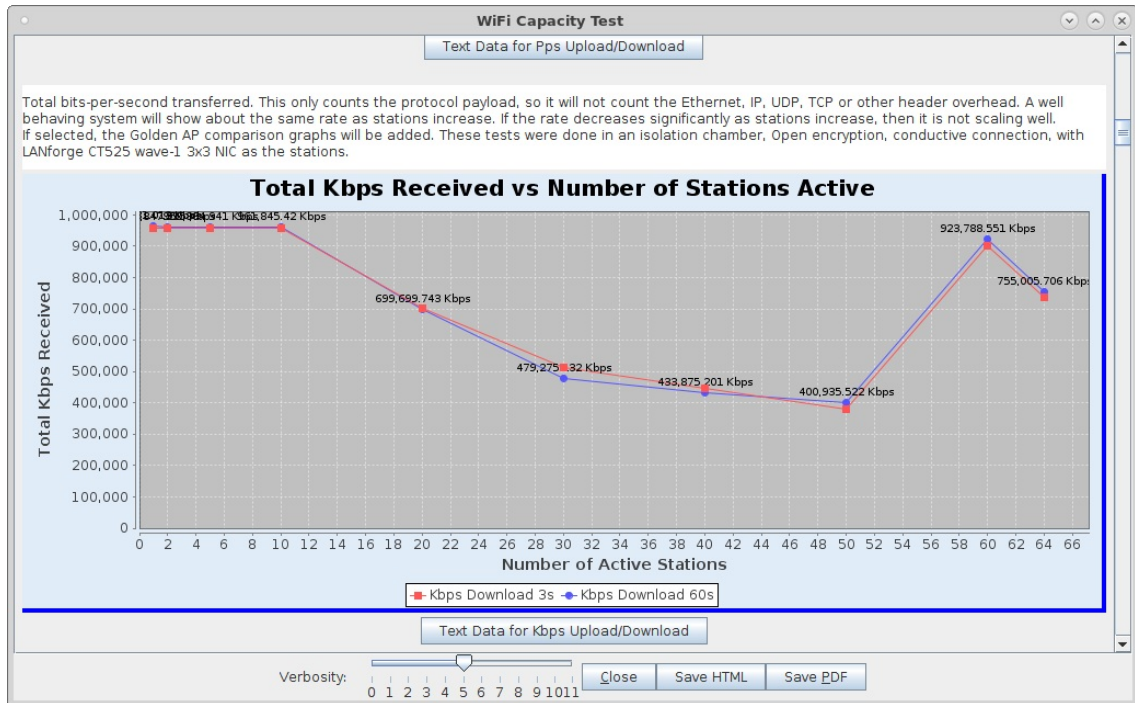

- D. When the test is complete, click the **Save HTML** button to save an HTML report and generate the PDF. The PDF file will be linked from the HTML page. You can also click 'Save PDF' and the browser will be directed to open the pdf file directly. Please see this [example WiFi Capacity Test Report](#).